

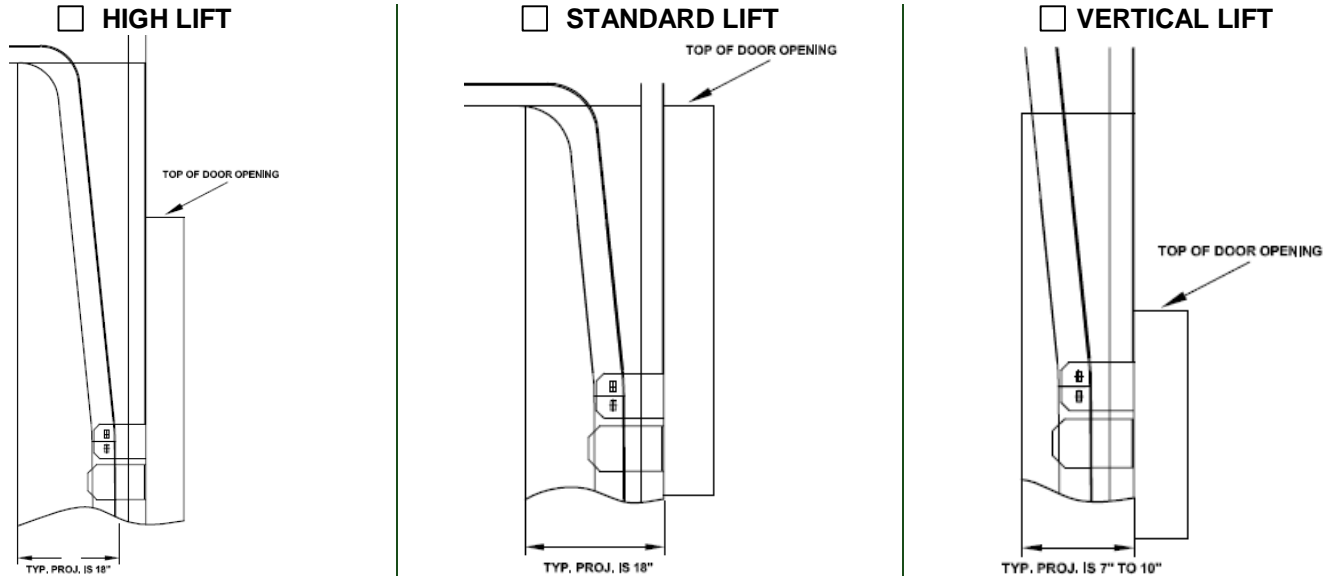

# Stand-Off Mount Survey

TO INSTALL A GATEWAY ROLL-UP DOOR IN FRONT OF AN EXISTING VERTICAL, SECTIONAL, OR OTHER DOOR

1) EXISTING DOOR TYPE



2) DOOR OPENING MEASUREMENT:

Wide x  High

3) OUT-TO-OUT TRACK DIMENSIONS

A. At the bottom of the track

B. At the top of the track

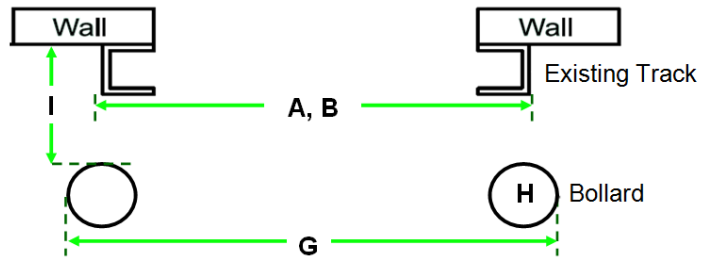

4) TRACK PROJECTION FROM WALL

C. At the bottom of the track

D. At header

E. 8 Inches above the header

F. 18 Inches above the header

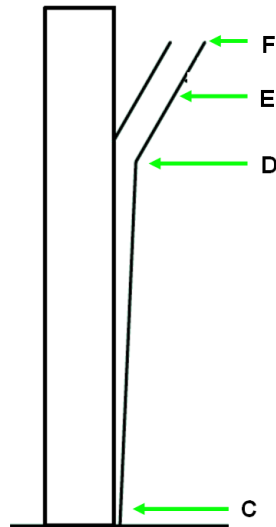

5) IF BOLLARDS

NOTE: Your Gateway door will project (E) + 2" or (F) + 2" out from the wall. If (I) is less than (E) + 2" or (F) + 2", please contact a Gateway Sales Rep to determine the best course of action.

G. Out-to-Out of Bollards

H. Bollard diameter

I. From wall to front of bollard