



GATEWAY INDUSTRIAL PRODUCTS, INC

# DOCK SEALS & SHELTERS



## **GATEWAY DOCK SEAL**

- > Standard Compression Seals Ideal for Openings Up to 10' W x 10' H
- > Promotes Dock Safety and Energy Savings with 80%-90% Sealing Efficiency

## **GATEWAY DOCK SHELTER**

- > "Drive-In" Shelter Ideal for 10' W x 10' H and Larger Openings
- > Protects Personnel, Equipment, and Merchandise from Rain, Snow and Wind

***Applications include retail, warehouses, and general manufacturing.***

## DOCK SEALS OVERVIEW

Gateway Dock Seals compress to form a positive seal between the truck and building. Recommended projection is 4"-6" past existing dock levelers, bumpers or other obstacles.

### BENEFITS

- > **Energy Savings:** Dock Seals boast an 80-90% sealing efficiency.
- > **Protection:** Protect building structure against trucks backing in.
- > **Dock Safety:** Helps prevent debris/ice buildup at loading dock, which improves safety.
- > **Climate Control:** Helps control dock temperatures improving employee comfort.
- > **Easy Install:** Brackets attach to opening and building face.

### CONSTRUCTION

- > **Head Piece**, closes opening to seal a standard 13' 6" trailer.
- > **(2) Side Pads** close opening width to 7' 4" – 7' 6" to seal a standard trailer.
  - **Polyurethane Foam** protects the building while allowing compression.
  - Vinyl is wrapped and stapled around lumber backboard for durable construction.
  - **Air Vents** release pressure when foam is compressed.
  - **Standard Yellow Safety Stripes** guide trucks as they back into the opening, or optional **40 oz. Vinyl Wear Pleats** can be individually sewn to the face of the side pad to provide additional durability and protection.
- > **Steel Angle Mounting Brackets** are included for easy installation.
- > Projection up to 22".
- > **Angled Side Pads** available for sloped docks.

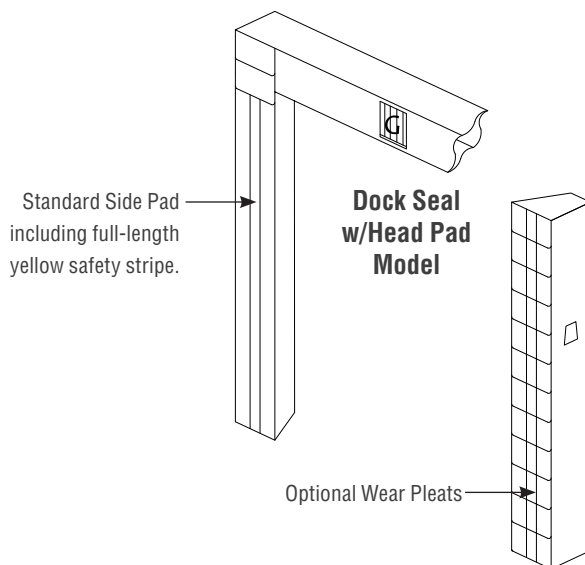

Shown: Standard Dock Seal (NO PLEATS) Full Yellow Guide Stripe.

### DOCK SEAL OPTIONS

#### VINYL OPTIONS

- > **22 Ounce Vinyl:** Recommended for light to medium duty applications.
- > **40 Ounce Vinyl:** Offers great resistance to abrasion, recommended for medium to heavy applications.

#### HEAD PIECE OPTIONS

**Foam Head Pad:** Recommended for openings up to 9' H.

**Face:** 12", 18", 24". Includes pleats for durability.

**Fixed Head Curtain:** Recommended for openings over 8' H.

**Face:** 12", 24", 36". Includes slits for relief when truck backs in, and pleats for durability.

**Adjustable Head Curtain:** Recommended for docks that service many different trailer heights. Made with slits for relief, pleats for durability. Rope and pulleys make height adjustable. Max Drop: 48".

**Wear Pleats:** 40 ounce vinyl pleats are optional for added protection on the side pads and corner of the head pad.

- > 4" Exposure for heavy use
- > 8" Exposure for medium use
- > 16" Exposure for light use



Shown: Wear Pleats (Yellow Bottom 32" Only).

## DOCK SHELTERS OVERVIEW

Gateway Dock Shelters are a “drive-in” shelter. When trucks back into the shelter, the curtain panels wrap around the sides and top to create a weather tight seal. The shelter design allows full access to the truck opening.

### BENEFITS

- > **Energy Savings:** Dock Shelters boast 65-80% sealing efficiency.
- > **Protection:** Prevent building structure damage from trucks.
- > **Dock Safety:** Helps prevent debris/ice buildup at loading dock, which improves safety.

### CONSTRUCTION

- > **Curtains:** Manufactured with premium 40 oz. Vinyl.
  - Protective **Wear Pleats** on the head curtain and bottom of side curtain for long-lasting wear.
  - **Side Curtains** close to 90° to seal around trucks without obstructing opening.
  - **Fiberglass Stays** sewn into protective pockets on side and head curtains provide positive contact against the top and sides of the truck.
- > **Frame:** Pressure-treated Wolmanized Lumber Frame is covered on top and sides with white 22 oz. vinyl panels to allow natural light into the loading area.
  - Standard **Top Frame** is steepled to allow run-off.
- > **Trim:** Aluminum Angle Trim provides finished look.
- > **Draft Pads:** Foam cushions with “No Step” warnings close gap between the side curtains and end of dock.
- > **Steel Bumpers:** Powder Coated Safety Yellow Steel Channel Bumpers support the shelter frame.

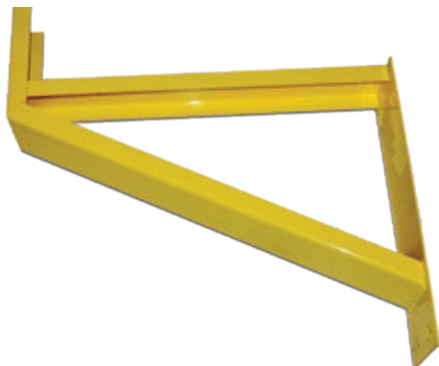
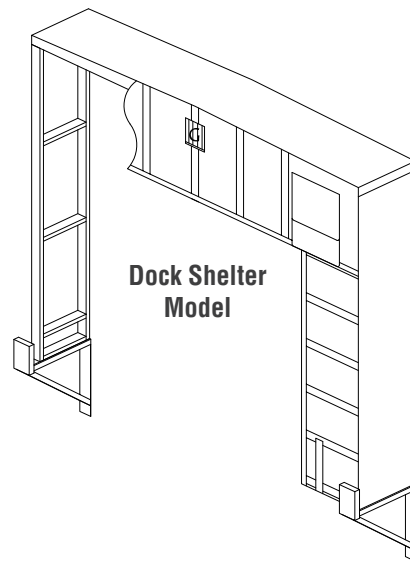

Shown: Standard 27" Yellow Steel Bumper.

# DOCK SEALS & SHELTERS SURVEY

## 1) INFORMATION

A. Company: \_\_\_\_\_ C. Quote #: \_\_\_\_\_  
 B. Job Name: \_\_\_\_\_ D. Door Name: \_\_\_\_\_

## 2) DOOR OPENING MEASUREMENT

Dock Seal       Dock Shelter

## OPENING

Wide \_\_\_\_\_ High \_\_\_\_\_

## 3) CLEARANCE

E. Left Side Clearance: \_\_\_\_\_  
 F. Right Side Clearance: \_\_\_\_\_  
 G. Top Clearance: \_\_\_\_\_

## 4) DOCK INFORMATION

H. Dock Height: \_\_\_\_\_  
 I. Bumper/EOD Projection: \_\_\_\_\_  
 J. Extension from Building \_\_\_\_\_  
*(Not including Bumpers)*  
 K. Dock Approach:     Level  
                                Incline  
                                Decline

## 5) IF INCLINE OR DECLINE: DOCK APPROACH

*Move as far from the dock as possible to take the following measurements:*

L. Distance from Dock (recommended 50'): \_\_\_\_\_  
 M. Dock Height at this Distance: \_\_\_\_\_

## 6) TRAFFIC INFORMATION

N. Standard Trailer Height: \_\_\_\_\_  
 O. Standard Trailer Width: \_\_\_\_\_

## 7) MATERIALS & OPTIONS

P. Vinyl Material:     22 oz.     40 oz.  
 Q. Head Piece:         Head Pad *(Dock Seals only)* up to 9' H  
                                Head Curtain  
                                    Standard  
                                    Adjustable  
 R. Optional Wear Pleats:     Yes     No  
     > Pleat Exposure:     4"     8"     16"  
     > Yellow Pleat Stripe:     Yes     No

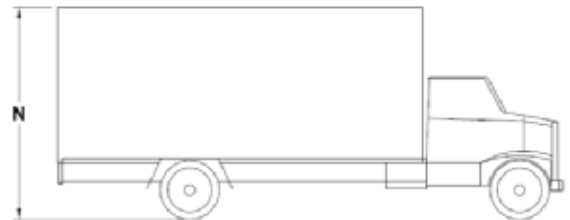
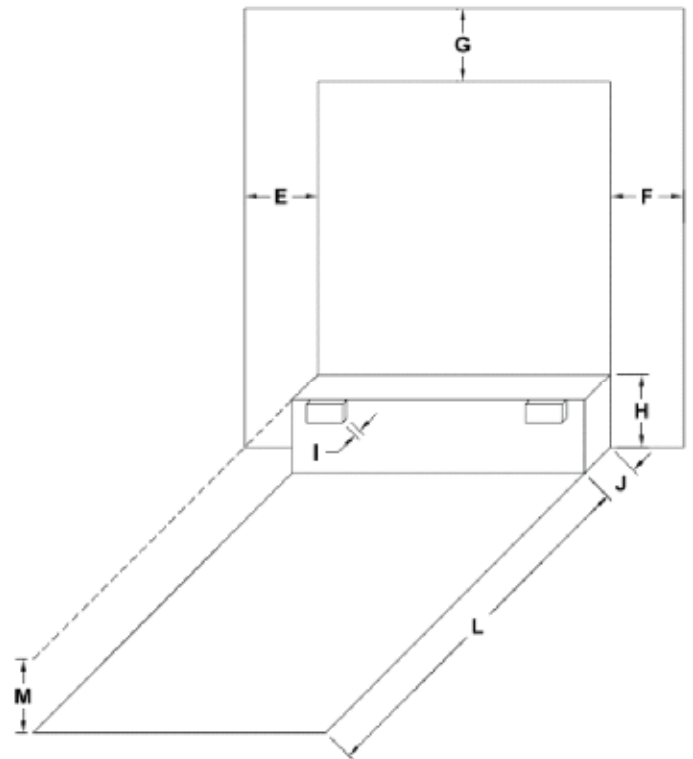

For more information visit [www.gatewayindustrial.com](http://www.gatewayindustrial.com) or call 1-800-701-4782

Gateway Industrial Products Inc. • 440.324.4112 • Fax 1.800.525.3427 • PO Box 95 Elyria, OH 44036